



93000 Series Mini Tilt-Curved Front Refrigerated Display Cases



Features & Finishes:	
<ul style="list-style-type: none"> • Tilt-Out Curved Front Glass • Solid Work Top Surface • Framed, Sliding, Insulated Mirror Doors • Top Light with Lamp and Shield • Heavy Duty Deck - White Finish • Heavy Duty Steel Base • White Wire Shelves 7 1/2° Slanted • Mirror Ends • White HPL Exterior Finish • Self-Contained Air-Cooling Unit in Base • Removable for Ease of Maintenance and Cleaning • 120 Volt - 60 Cycle - Single Phase • 1/3 HP - 10 Amps • Automatic, Energy Saving, Condensate Evaporator • 10' Cord, Plug & Switch • U.L. & C.U.L. Listed • "ETL" Sanitation Listed (Conforms to NSF STD - 7) 	
Designed to Operate in a Controlled Environment of 75° F Ambient / 55% Relative	
	

93000 Series Mini Tilt-Curved Front Refrigerated Display Cases

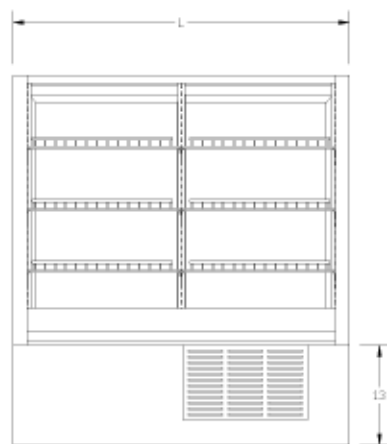
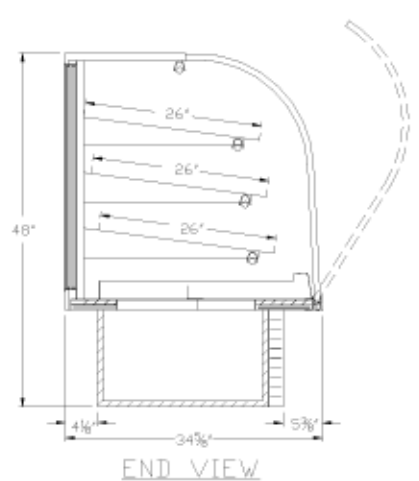
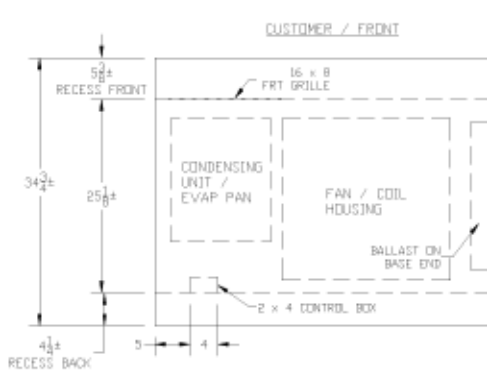
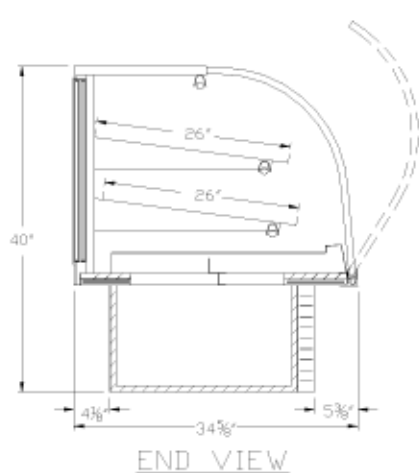

Model No.	Dimensions: L X D X H	Rows of Shelves	Est. Crated	Pan Capacity	Case Options:
93040-36R	36" x 34 3/4" x 40"	2	680 lbs.	3 Full/3 Half	1. Brasstone or Black Finish (Frame, Hardware, Lights & Shelves) 2. Brasstone or Black Finish (Frame & Lights only) 3. Transparent Mirror Doors 4. Std. HPL Exterior Finish 5. Shelf Light (s) with Lamp (s) & Shield (s) 6. Remote Compressor (Shipped Separately) 7. Casters or Legs (Shipped Separately) 8. 4-Yr. Extended Motor/Compressor Parts Warranty
93048-36R	36" x 34 3/4" x 48"	3	700 lbs.	4 Full/4 Half	

Specifications Subject to change without notice

